



United States Court of Appeals for the Federal Circuit

AUTOMOTIVE BODY PARTS ASSOCIATION,
Plaintiff-Appellant

v.

FORD GLOBAL TECHNOLOGIES, LLC,
Defendant-Appellee

2018-1613

Appeal from the United States District Court for the Eastern District of Michigan in No. 2:15-cv-10137-LJM-RSW, Judge Laurie J. Michelson.

SEALED OPINION ISSUED: July 11, 2019
PUBLIC OPINION ISSUED: July 23, 2019*

ROBERT GLENN OAKE, JR., Oake Law Office, Allen, TX, argued for plaintiff-appellant. Also represented by PAUL KITTINGER, Cardelli Lanfear PC, Royal Oak, MI.

JESSICA LYNN ELLSWORTH, Hogan Lovells US LLP, Washington, DC, argued for defendant-appellee. Also represented by KATHERINE BOOTH WELLINGTON; FRANK A.

* This opinion was originally filed under seal and has been unsealed in full.

ANGILERI, MARC LORELLI, Brooks Kushman PC, Southfield, MI.

Before HUGHES, SCHALL, and STOLL, *Circuit Judges*.

STOLL, *Circuit Judge*.

This case involves both differences and similarities between design patents and utility patents. A design patent protects a “new, original and ornamental design for an article of manufacture.” 35 U.S.C. § 171(a). While established law bars design patents on primarily functional designs for lack of ornamentality, utility patents must be functional to be patentable. In many other ways though, design and utility patents are similar. Section 171(b) of Title 35 demands as much, directing that the requirements that apply to “patents for inventions shall apply to patents for designs” unless otherwise provided.

Here, we decide what types of functionality invalidate a design patent and determine whether long-standing rules of patent exhaustion and repair rights applicable to utility patents also apply to design patents. Automotive Body Parts Association (ABPA) asks us to hold that the aesthetic appeal—rather than any mechanical or utilitarian aspect—of a patented design may render it functional. And it asks us to expand the doctrines of exhaustion and repair to recognize the “unique nature” of design patents. Both theories invite us to rewrite established law to permit ABPA to evade Ford Global Technologies, LLC’s patent rights. We decline ABPA’s invitation and affirm the district court’s summary judgment.

BACKGROUND

I

Ford’s U.S. Patent No. D489,299 and U.S. Patent No. D501,685 protect designs used in certain models of Ford’s F-150 trucks. The D’299 patent, titled “Exterior of

Vehicle Hood,” claims “[t]he ornamental design for exterior of vehicle hood.” Figure 1, below, illustrates the hood.

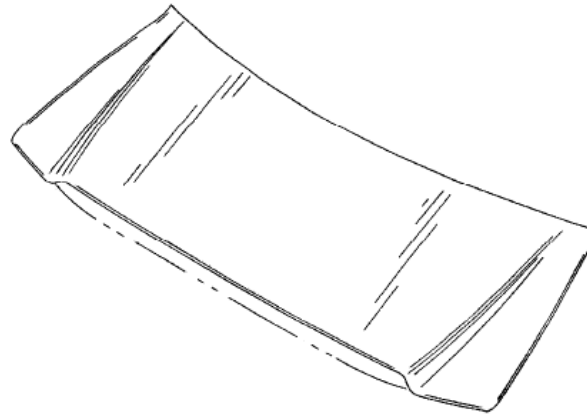

FIG. 1

The D’685 patent, titled “Vehicle Head Lamp,” claims “[t]he ornamental design for a vehicle head lamp,” as shown in Figures 1 and 2, reproduced below.

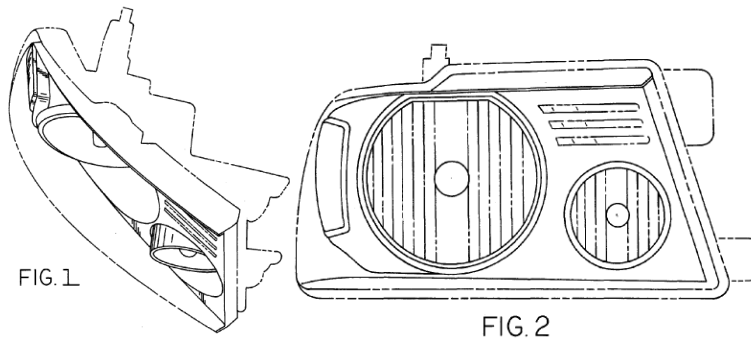

FIG. 1

FIG. 2

The inventors of these designs are artists holding Bachelor of Fine Arts degrees from the College for Creative Studies. In a declaration, one inventor explained that the inventors had “full control and responsibility for the exterior appearance of the . . . Ford F-150 truck,” that “the design team created and selected part designs based on aesthetic appearance,” and that although engineers reviewed the final designs, “[t]here were no changes to the aesthetic

designs of the[] parts based on engineering or functional requirements.” J.A. 2538–39.

II

ABPA, an association of companies that distribute automotive body parts, clashed with Ford at the International Trade Commission when Ford accused a number of ABPA members of infringing the D’299 and D’685 patents, among others. The ITC actions eventually settled, but only after the administrative law judge ruled that “respondents’ [invalidity] defense that the asserted patents do not comply with the ornamentality requirement of 35 U.S.C. § 171 has no basis in the law,” J.A. 256, and that “there is no legal basis for respondents’ assertion of [unenforceability based on] either the patent exhaustion or permissible repair doctrines,” J.A. 242.

Undeterred, ABPA sued Ford in district court, seeking a declaratory judgment of invalidity or unenforceability of the D’299 and D’685 patents. ABPA eventually moved for summary judgment. The district court considered ABPA’s arguments and denied the motion, noting that ABPA “effectively ask[ed] this Court to eliminate design patents on auto-body parts.” *Auto. Body Parts Ass’n v. Ford Glob. Techs., LLC*, 293 F. Supp. 3d 690, 694 (E.D. Mich. 2018). Though Ford had not moved for summary judgment, the district court announced its intention to enter judgment in favor of Ford sua sponte pursuant to Federal Rule of Civil Procedure 56(f)(1). *Id.* at 707. ABPA responded, agreeing that it had not “include[d] any additional argument, authorities, or evidence beyond that which has already been considered by this Court,” and stating that it “d[id] not object to the prompt entry of final judgment so that [it could] file a notice of appeal.” J.A. 2149. The district court entered summary judgment, and ABPA appeals.

DISCUSSION

We review the district court's sua sponte grant of summary judgment under the law of the regional circuit. See *Charles Mach. Works, Inc. v. Vermeer Mfg. Co.*, 723 F.3d 1376, 1378 (Fed. Cir. 2013). In the Sixth Circuit, “[t]he substance of the district court’s decision is reviewed de novo under the normal standards for summary judgment.” *Leffman v. Sprint Corp.*, 481 F.3d 428, 430 (6th Cir. 2007) (“The district court’s procedural decision to enter summary judgment sua sponte, however, is reviewed for abuse of discretion.” (quoting *Shelby Cty. Health Care Corp. v. S. Council of Indus. Workers Health & Welfare Trust Fund*, 203 F.3d 926, 931 (6th Cir. 2000))). Accordingly, we determine whether, after weighing all inferences in favor of ABPA, Ford is entitled to judgment as a matter of law.¹ See *Leary v. Daeschner*, 349 F.3d 888, 897 (6th Cir. 2003).

I

We first address ABPA’s invalidity arguments. Section 171 of Title 35 authorizes patents claiming “new, original and *ornamental* design[s] for an article of manufacture.” 35 U.S.C. § 171(a) (emphasis added). Our precedent gives weight to this language, holding that a design patent must claim an “ornamental” design, not one “dictated by function.” See, e.g., *High Point Design LLC v. Buyers Direct, Inc.*, 730 F.3d 1301, 1315 (Fed. Cir. 2013). We have recognized, however, that a valid design may contain some functional elements. After all, “a design patent’s

¹ Ordinarily, we review a district court’s determination of whether a patented design is invalid due to functionality for clear error. See *Ethicon Endo-Surgery, Inc. v. Covidien, Inc.*, 796 F.3d 1312, 1328 (Fed. Cir. 2015). ABPA invites us to revisit this standard and establish de novo review. Given the de novo standard inherent in review of summary judgment, we do not reach this question.

claim protects an article of manufacture, which ‘necessarily serves a utilitarian purpose.’” *See Sport Dimension, Inc. v. Coleman Co.*, 820 F.3d 1316, 1320 (Fed. Cir. 2016) (quoting *L.A. Gear, Inc. v. Thom McAn Shoe Co.*, 988 F.2d 1117, 1123 (Fed. Cir. 1993)). But a design patent may not claim a “primarily functional” design. *Id.* “If [a] particular design is essential to the use of the article, it can not be the subject of a design patent.” *L.A. Gear*, 988 F.2d at 1123.

While “[w]e have not mandated applying any particular test,” certain considerations assist courts in assessing whether a design is dictated by function. *Ethicon*, 796 F.3d at 1329. These include:

[W]hether the protected design represents the best design; whether alternative designs would adversely affect the utility of the specified article; whether there are any concomitant utility patents; whether the advertising touts particular features of the design as having specific utility; and whether there are any elements in the design or an overall appearance clearly not dictated by function.

Berry Sterling Corp. v. Pescor Plastics, Inc., 122 F.3d 1452, 1456 (Fed. Cir. 1997). We have often emphasized the presence or absence of alternative designs, noting that the existence of “several ways to achieve the function of an article of manufacture,” though not dispositive, increases the likelihood that a design serves a primarily ornamental purpose. *Id.* (quoting *L.A. Gear*, 988 F.2d at 1123); *see also Nordock, Inc. v. Sys. Inc.*, 803 F.3d 1344, 1361 (Fed. Cir. 2015) (affirming ornamentality where record showed “alternate designs available achieve the same utilitarian purpose”), *vacated on other grounds*, 137 S. Ct. 589 (2016); *Rosco, Inc. v. Mirror Lite Co.*, 304 F.3d 1373, 1378 (Fed. Cir. 2002) (“[I]f other designs could produce the same or similar functional capabilities, the design of the article in question is likely ornamental, not functional.”).

A

ABPA posits (without record support) that consumers seeking replacement parts prefer hoods and headlamps that restore the original appearance of their vehicles. It concludes that there is a functional benefit to designs that are aesthetically compatible with those vehicles. *See, e.g.*, Appellant's Br. 8–9 (“The function of the claimed designs includes their appearance . . .”). From there, rather than arguing that Ford's designs are functional because they achieve some mechanical or utilitarian goal, ABPA argues that Ford's hood and headlamp designs are functional because they aesthetically match the F-150 truck. But ABPA does not identify, nor can we find, any design patent case ruling aesthetic appeal of this type functional.

We hold that, even in this context of a consumer preference for a particular design to match other parts of a whole, the aesthetic appeal of a design to consumers is inadequate to render that design functional. As the Supreme Court acknowledged almost 150 years ago, “giving certain new and original appearances to a manufactured article may enhance its salable value, [and] may enlarge the demand for it.” *Gorham Mfg. Co. v. White*, 81 U.S. 511, 525 (1871). But regardless of the market advantage conferred by a patented appearance, competitors may not utilize a protected design during the patent's life. *See id.*; *see also* 35 U.S.C. § 289. To hold that designs that derive commercial value from their aesthetic appeal are functional and ineligible for protection, as ABPA asks, would gut these principles. The very “thing . . . for which [the] patent is given, is that which gives a peculiar or distinctive appearance,” its aesthetic. *Gorham*, 81 U.S. at 525. If customers prefer the “peculiar or distinctive appearance” of Ford's designs over that of other designs that perform the same mechanical or utilitarian functions, that is exactly the type of market advantage “manifestly contemplate[d]” by Congress in the laws authorizing design patents. *Id.*

B

ABPA's contrary arguments are unpersuasive. It first asks us to borrow the principle of "aesthetic functionality" from trademark law. In that context, courts have explained that a party cannot use trademark protection to prevent its competitors from using "important product ingredient[s]," *Qualitex Co. v. Jacobson Prods. Co.*, 514 U.S. 159, 170 (1995), or "from making their products as visually entrancing as [its] own," *Pub'ns Int'l, Ltd. v. Landoll, Inc.*, 164 F.3d 337, 339 (7th Cir. 1998) (Posner, J.) (explaining that trademark and trade dress protection are unavailable "if consumers derive a value from the fact that a product looks a certain way that is distinct from the value of knowing at a glance who made it"). In *Qualitex*, the Supreme Court permitted a party to trademark a particular color only after explaining that protection might not be available if the "color serve[d] a significant nontrademark function." *Qualitex*, 514 U.S. at 170.

ABPA acknowledges that no court has applied "aesthetic functionality" to design patents, but it asks us to become the first. Appellant's Br. 28–29. We decline. Though trademarks and design patents have certain similarities, *see id.* at 29–30, it does not follow that trademark principles apply equally to design patents. Trademarks and design patents serve different purposes and have different governing law. Trademarks promote competition by permitting a perpetual monopoly over symbols that "distinguish[] a firm's goods and identif[y] their source, without serving any other significant function." *Qualitex*, 514 U.S. at 166. Trademarks ensure that a particular producer reaps the rewards—and bears the risks—of its products' quality and desirability. *See id.* at 163–64. It follows that a company may not indefinitely inhibit competition by trademarking features, whether utilitarian or aesthetic, "that either are not associated with a particular producer or that have value to consumers that is independent of identification." *Pub'ns Int'l*, 164 F.3d at 339; *see also*

Qualitex, 514 U.S. at 164–65 (holding companies may not “inhibit[] legitimate competition” by trademarking desirable features to “put competitors at a significant non-reputation-related disadvantage”). In contrast, design patents expressly grant to their owners exclusive rights to a particular aesthetic for a limited period of time. *See Qualitex*, 514 U.S. at 164; *see also* U.S. Const. art. I, § 8, cl. 8. The considerations that drive the aesthetic functionality doctrine of trademark law simply do not apply to design patents.

ABPA also attempts to justify its functionality argument with reference to our case law, but it misunderstands our precedent. In *Best Lock Corp. v. Ilco Unican Corp.*, 94 F.3d 1563 (Fed. Cir. 1996), we considered a design patent for a key “blade,” the portion of the key that interacts with a lock to open or close it. *Id.* at 1564. The parties agreed that “the key blade must be designed as shown in order to perform its intended function—to fit into its corresponding lock’s keyway. An attempt to create a key blade with a different design would necessarily fail because no alternative blank key blade would fit the corresponding lock.” *Id.* at 1566. On those facts, we affirmed the district court’s finding that the claimed key blade design was dictated solely by function, and the design patent was invalid. *Id.* ABPA argues that only Ford’s patented designs aesthetically “match” the F-150,² and attempts to analogize *Best Lock* to the instant case. But *Best Lock* turned on the admitted fact that no alternatively designed blade would mechanically operate the lock—not that the blade and lock

² ABPA also briefly suggests that insurers require repair parts to use Ford’s original designs with the F-150 but cites no evidentiary support. ABPA’s own witness explained that insurers simply pay a sum of money for repairs; they do not dictate whether a repair is even made. J.A. 1312.

were aesthetically compatible. *Id.*; see also *Static Control Components, Inc. v. Lexmark Int'l, Inc.*, 697 F.3d 387, 395, 422 (6th Cir. 2012) (holding a printer cartridge design functional where “each company’s cartridges will work with only its brand of printers” and “the design of the printer dictated the exact design of the cartridge”).

Best Lock is distinguished for yet another reason. Ford introduced abundant evidence of alternative headlamp and hood designs that physically fit its trucks. See *Auto. Body Parts*, 293 F. Supp. 3d at 703 (reproducing images); J.A. 2442–43. ABPA’s own witnesses testified to the existence of “performance parts” that have a different “design or shape” than the manufacturer’s parts so that they have “some aesthetic appeal or something like that.” J.A. 940–41; see also J.A. 1312–13 (testifying that customers select performance parts because “[t]hey want [their vehicles] to look different”). And ABPA admitted that a “performance part” “will fit the associated vehicle . . . but may differ in appearance from the original part.” J.A. 1330; see also J.A. 1340 (same). On these facts, *Best Lock* bears little similarity to this case.

Similarly, ABPA urges us to rule that Ford’s designs are not a “matter of concern” to consumers. We have explained that a design is generally not a “matter of concern,” and lacks ornamentality, if it may not be observed or if it is assessed only for functionality. See *In re Webb*, 916 F.2d 1553, 1557–58 (Fed. Cir. 1990). ABPA avers that consumers assess Ford’s designs only to assess their aesthetic compatibility with the F-150. But by definition, if a consumer assesses the aesthetic of a design in considering whether to purchase it, the design *is* a matter of concern. See *id.* Indeed, ABPA and its witnesses admitted that customers select replacement parts from among multiple different designs based on their preferred aesthetic, further undermining ABPA’s position. See J.A. 940–41, 1312–13, 1330, 1340. And regardless, the district court found that “it is beyond reasonable debate that the design of an auto-body

part is important to consumers at least when they are deciding which car to buy.” *Auto. Body Parts*, 293 F. Supp. 3d at 701. ABPA fails to explain how that well-supported finding constitutes error.

Finally, ABPA asks this court to rule, as a matter of policy, that Ford’s design patents may be enforced only in the initial market for sale of the F-150, and not in the market for replacement components. Appellant’s Br. 36. ABPA argues that a market-specific rule is appropriate because customers have different concerns in different contexts. It declares that customers care about design in the initial sales market, but not when they select replacement parts. But ABPA cites no supporting facts. Instead, it ignores abundant record evidence regarding performance parts available as replacements for customers who “want [their vehicles] to look different.” J.A. 1312–13. It cites no patent case to support its argument. And it seeks to sidestep our precedent, which asks “whether *at some point* in the life of the article an occasion (or occasions) arises when the appearance of the article becomes a ‘matter of concern.’” *Webb*, 916 F.2d at 1557 (emphasis added). Finding neither legal nor factual support for ABPA’s argument, we reject it.³ We therefore affirm the district court’s determination that ABPA failed, as a matter of law, to prove Ford’s designs functional by clear and convincing evidence. *See Ethicon*, 796 F.3d at 1328 (discussing burden and standard of proof).

³ A bill seeking to create a market-based analysis specifically for auto-body design patents was introduced in a previous Congress but has not become law. *See* PARTS Act, S. 780, 113th Cong. (2013); J.A. 664. “[I]t is not our job to apply laws that have not yet been written.” *See Sony Corp. of Am. v. Universal City Studios, Inc.*, 464 U.S. 417, 456 (1984).

II

We next address ABPA's contention that Ford's patents are unenforceable against its members under the related doctrines of exhaustion and repair.

A

"The franchise which the patent grants, consists altogether in the right to exclude every one from making, using, or vending the thing patented, without the permission of the patentee." *Bloomer v. McQuewan*, 55 U.S. 539, 549 (1852). But when the patentee sells his invention, the thing sold "is no longer within the limits of the monopoly." *Id.*; see also *United States v. Masonite Corp.*, 316 U.S. 265, 277–78 (1942). This "well-established" rule, dubbed exhaustion, "marks the point where patent rights yield to the common law principle against restraints on alienation." *Impression Prods., Inc. v. Lexmark Int'l, Inc.*, 137 S. Ct. 1523, 1531 (2017). An authorized sale compensates the patentee for his invention. After such a sale, the patentee may no longer "control the use or disposition' of the product." *Id.* (quoting *United States v. Univis Lens Co.*, 316 U.S. 241, 250 (1942)). And the purchaser may use or dispose of that product without incurring liability for infringement. See, e.g., *ExcelStor Tech., Inc. v. Papst Licensing GMBH & Co. KG*, 541 F.3d 1373, 1376 (Fed. Cir. 2008) ("patent exhaustion is a defense to patent infringement").

Ford concedes that when it sells an F-150, its patents are exhausted as to the components actually sold as part of that truck. Oral Arg. at 17:58–18:24, <http://oralarguments.cafc.uscourts.gov/default.aspx?fl=2018-1613.mp3>. ABPA argues that exhaustion extends further, asserting that the sale of an F-150 truck totally exhausts any design patents embodied in the truck and permits use of Ford's designs on replacement parts so long as those parts are intended for use with Ford's trucks. See Appellant's Br. 43–45. But exhaustion attaches only to items sold by, or with the authorization of, the patentee. See *Jazz Photo Corp. v.*

Int'l Trade Comm'n, 264 F.3d 1094, 1105 (Fed. Cir. 2001) (explaining that an authorized sale “exhausts’ the patentee’s right to control further sale and use of *that article*” but does not permit a “second creation of the patented entity” (emphasis added)), *overruled on other grounds by Impression Prod.*, 137 S. Ct. at 1538; *see also Bowman v. Monsanto Co.*, 569 U.S. 278, 286 (2013) (“The exhaustion doctrine is limited to the ‘particular item’ sold . . .”). ABPA’s members’ sales are not authorized by Ford; it follows that exhaustion does not protect them. *See Helferich Patent Licensing, LLC v. N.Y. Times Co.*, 778 F.3d 1293, 1302 (Fed. Cir. 2015) (“[T]he decisions finding exhaustion . . . have done so *only* when . . . *an authorized acquirer* was using the same invention by infringing the asserted claims.” (emphases added)).

ABPA asks us to “adapt[]” this rule for design cases. *See* Appellant’s Br. 49. But we apply the same rules to design and utility patents whenever possible. *See* 35 U.S.C. § 171(b) (“The provisions of this title relating to patents for inventions shall apply to patents for designs, except as otherwise provided.”). Accordingly, we have held that principles of prosecution history estoppel, inventorship, anticipation, and obviousness apply to both design patents and utility patents. *See, e.g., Pac. Coast Marine Windshields Ltd. v. Malibu Boats, LLC*, 739 F.3d 694, 702 (Fed. Cir. 2014) (“The same principles of public notice that underlie prosecution history estoppel apply to design patents as well as utility patents.”); *Hoop v. Hoop*, 279 F.3d 1004, 1007 (Fed. Cir. 2002) (“We apply the same standard of inventorship to design patents that we require for utility patents.”); *Hupp v. Siroflex of Am., Inc.*, 122 F.3d 1456, 1461 (Fed. Cir. 1997) (“In determining whether a design patent is invalid based on a description in a printed publication, . . . the factual inquiry is the same as that which determines anticipation by prior publication of the subject matter of a utility patent”); *In re Borden*, 90 F.3d 1570, 1574 (Fed. Cir. 1996) (“Design patents are subject to the

same conditions on patentability as utility patents, including the nonobviousness requirement of 35 U.S.C. § 103.”). We see no persuasive reason to depart from this standard for the exhaustion doctrine.

ABPA points to the Supreme Court’s decision in *Quanta Computer, Inc. v. LG Electronics, Inc.*, 553 U.S. 617 (2008), to assert that we should nevertheless create a design-patent-specific rule for exhaustion. Appellant’s Br. 49. In *Quanta*, the Court rejected an attempt to exempt method claims from exhaustion. *See Quanta*, 553 U.S. at 628. After reviewing the history and purpose of the doctrine, the Court noted that “[o]ur precedents do not differentiate transactions involving embodiments of patented methods or processes from those involving patented apparatuses or materials.” *Id.* at 628–29. It therefore held that like other utility patents, method patents are exhausted by the authorized sale of an item embodying the claimed invention. *Id.* at 638. And accordingly, it determined that the sale of a microprocessor embodying a method patent exhausts that patent. *See id.* It did not, however, hold that purchasers of those microprocessors could make their own, new microprocessors using the patented invention, as ABPA suggests. Far from supporting ABPA’s position, *Quanta* supports our reluctance to establish special rules for design patents—our precedents do not differentiate transactions involving embodiments of patented designs from those involving patented processes or methods. *See, e.g., Jazz Photo*, 264 F.3d at 1110 (“[T]he principle of exhaustion applies to the design patents as well as to the utility patents.”).

B

ABPA’s right of repair argument is equally unpersuasive. The right of use transferred to a purchaser by an authorized sale “include[s] the right to repair the patented article.” *Kendall Co. v. Progressive Med. Tech., Inc.*, 85 F.3d 1570, 1573 (Fed. Cir. 1996). The right of repair

does not, however, permit a complete reconstruction of a patented device or component. See *Helperich*, 778 F.3d at 1303–05 (noting purchaser cannot recreate patented product); *Kendall*, 85 F.3d at 1573–74 (explaining that while a purchaser may not undertake a “complete ‘reconstruction’” of the patented device, he may replace “individual *unpatented* components” of the patented article (emphasis added)). And it does not permit a purchaser to infringe other patents by manufacturing separately patented components of the purchased article. See *Aro Mfg. Co. v. Convertible Top Replacement Co.*, 365 U.S. 336, 346 (1961) (“[R]eplacement of a spent, *unpatented element* does not constitute reconstruction. The decisions of this Court require the conclusion that reconstruction of a patented entity, comprised of unpatented elements, is limited to such a true reconstruction of the entity as to ‘in fact make a new article’” (emphasis added) (quoting *United States v. Aluminum Co. of Am.*, 148 F.2d 416, 425 (2d Cir. 1945) (Hand, J.))); *Helperich*, 778 F.3d at 1303–05 (noting prohibition on reconstruction).

ABPA argues that purchasers of Ford’s F-150 trucks are licensed to repair those trucks using replacement parts that embody Ford’s hood and headlamp design patents. But straightforward application of long-standing case law compels the opposite conclusion. Over 150 years ago, a New Hampshire court considered facts similar to those of this case in *Aiken v. Manchester Print Works*, 1 F. Cas. 245 (C.C.D.N.H. 1865). There, the patentee sold a patented knitting machine whose needles wore out on a regular basis. *Id.* at 245–46. Though the needles were covered by a separate patent, the accused infringers argued that they could properly manufacture replacement needles to continue using the knitting machine they had purchased. The court disagreed, holding that “the needle is subject to a patent, and in making and using it they have infringed.” *Id.* at 247. It distinguished an earlier Supreme Court case in which a purchaser had been permitted to replace the

knives used in a patented cutting machine, noting “the cutters and knives, in [*Wilson v. Simpson*, 50 U.S. 109 (1850)], were not subject to a patent.” *Id.* The Supreme Court endorsed *Aiken*’s reasoning in *Morgan Envelope Co. v. Albany Perforated Wrapping Paper Co.*, 152 U.S. 425, 435–36 (1894), and its reasoning governs here. Ford’s patents claim “[t]he ornamental design for exterior of vehicle hood,” see D’299 patent, Claim, and “[t]he ornamental design for a vehicle head lamp,” see D’685 patent, Claim. The designs may be embodied in the hoods and headlamps that form part of the full F-150 truck or in separate hoods and headlamps. But though a sale of the F-150 truck permits the purchaser to repair the designs as applied to the specific hood and headlamps sold on the truck, the purchaser may not create new hoods and headlamps using Ford’s designs. Like the needles in *Aiken*, such new hoods and headlamps are subject to Ford’s design patents, and manufacturing new copies of those designs constitutes infringement.

ABPA attempts to distinguish *Aiken* and its progeny by asserting that these cases apply only to utility patents. ABPA urges us to adopt a new rule that recognizes the “unique nature” of design patents. See Appellant’s Reply Br. 18. In particular, ABPA claims that the statutory language authorizing design patents dictates such a rule. Unlike 35 U.S.C. § 101, which authorizes utility patents for a “process, machine, manufacture, or composition of matter, or any new and useful improvement thereof,” 35 U.S.C. § 171 permits design patents for a “design for an article of manufacture.” ABPA argues that because “article of manufacture,” is a term broad enough to include both a product component and the product itself, see *Samsung Elecs. Co. v. Apple Inc.*, 137 S. Ct. 429, 434 (2016), sale of either the component (i.e., the hood or headlamp) or the whole product (i.e., the F-150) totally exhausts a design patent and permits unlimited repair. See Appellant’s Br. 43–58.

We disagree. In our view, the breadth of the term “article of manufacture” simply means that Ford *could*

properly have claimed its designs as applied to the entire F-150 or as applied to the hood and headlamp. To determine what repair rights apply, we look to what Ford actually claimed. As always, “the name of the game is the claim.” *Arlington Indus., Inc. v. Bridgeport Fittings, Inc.*, 632 F.3d 1246, 1255 n.2 (Fed. Cir. 2011) (quoting Giles S. Rich, *The Extent of the Protection and Interpretation of Claims—American Perspectives*, 21 Int’l Rev. Indus. Prop. & Copyright L. 497, 499, 501 (1990)). Ford chose to claim designs as applied to portions of particular components, and the law permits it to do so. *See, e.g., Samsung*, 137 S. Ct. at 435; *Gorham*, 81 U.S. at 512. That the auto-body components covered by Ford’s patents may require replacement does not compel a special rule. Just as the patentee in *Aiken* could have only claimed the needles in conjunction with the knitting machine, Ford could have only claimed its design as applied to the whole truck. Unfortunately for ABPA, Ford did not do so; the designs for Ford’s hood and headlamp are covered by distinct patents, and to make and use those designs without Ford’s authorization is to infringe. *See Aiken*, 1 F. Cas. at 247.⁴

We thus reject ABPA’s attempts to develop design patent-specific exhaustion and repair rules.⁵ Consequently,

⁴ ABPA asserts that Ford’s purchasers are unaware of the design patents covering the hood and headlamp and suggests that as a result we should permit their use of the patented designs. Appellant’s Br. 56–57. Even if purchasers are unaware—and ABPA cites no factual support for that assertion—direct infringement does not require knowledge of a patent. *See Glob.-Tech Appliances, Inc. v. SEB S.A.*, 563 U.S. 754, 761 n.2 (2011) (“[A] direct infringer’s knowledge or intent is irrelevant.”).

⁵ As an additional argument for affirmance, Ford asserts that because ABPA and its members are not themselves the purchasers of Ford’s trucks, they cannot benefit

we affirm the district court's ruling that ABPA has not shown that Ford's designs for an F-150 hood and headlamp are exhausted when Ford sells an F-150 truck.

CONCLUSION

Having considered the parties' remaining arguments and found them unpersuasive, we affirm the district court.

AFFIRMED

COSTS

Costs to Appellee.

from an implied license to repair the trucks. *See* Appellee's Br. 43–45. For purposes of this opinion, we do not reach this issue.